



## VRLA Rechargeable Battery

# HR1234W (HR1234WFR)

### FEATURES

- Maintenance free(no water topping-up required)
- No free acid(Non-spillable battery)
- Can be used in any orientation(excluding used inverted)
- The battery is designed for high rate usage
- Its design life is 3~5 years in floating application at 77°F/25°C
- Absorbent Glass Mat technology for efficient gas recombination
- The power density at 5 min~15min discharging rate is 30% higher than BP series

### APPLICATION

- UPS
- Laboratory Equipment
- Fishing Lights
- Toy-Cars
- Power Packs



### SPECIFICATIONS

Nominal Voltage	12V	
Nominal Capacity	10 Hour Rate (700mA, 10.5V)	8.00 Ah
	15 Min Rate (204W, 7.8V)	4.25 Ah
Approx. Weight	2600g(5.73lbs.)	
Terminals	T2 (Faston Tab 250) T1 is optional	
Max. Discharge Current	105 A (5 sec.)	
Max. Charge Current	2.1 A	
Operating Temperature Range	Charge	0°C~40°C(32°F~104°F)
	Discharge	-20°C~50°C(-4°F~122°F)
	Storage	-20°C~40°C(-4°F~104°F)
Self Discharge	< 3% per month (25°C)	
Internal Resistance	≤20mΩ (Fully Charged)	

### CONTAINER MATERIAL

- HR1234W:  
ABS: UL 94-HB (Dark gray color)
- HR1234WFR:  
ABS: UL 94-V0 (Light gray color)

 ISO 9001	 ISO14001
 MH19884 UL	 C4M20310-2474-E-16 CE
<ul style="list-style-type: none"> <li>• IEC61056</li> <li>• GB/T 19639</li> </ul>	<ul style="list-style-type: none"> <li>• JIS C 8702</li> </ul>

### OUTER DIMENSIONS mm(inch)

Length (L)	Width (W)	Container Height (H)	Total Height (TH)
151±1.5(5.94±0.06)	65±1.5(2.56±0.06)	94±1.5(3.70±0.06)	100±2.0(3.94±0.08)

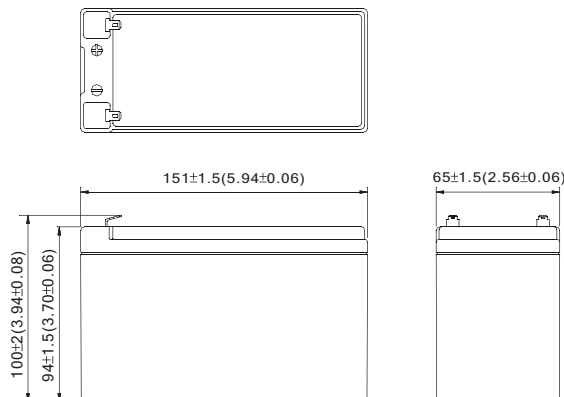

### TERMINAL TYPE

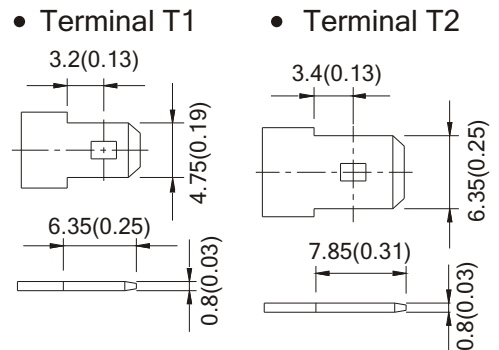

**HR1234W (HR1234WFR) discharge characteristics (25°C /77°F)**

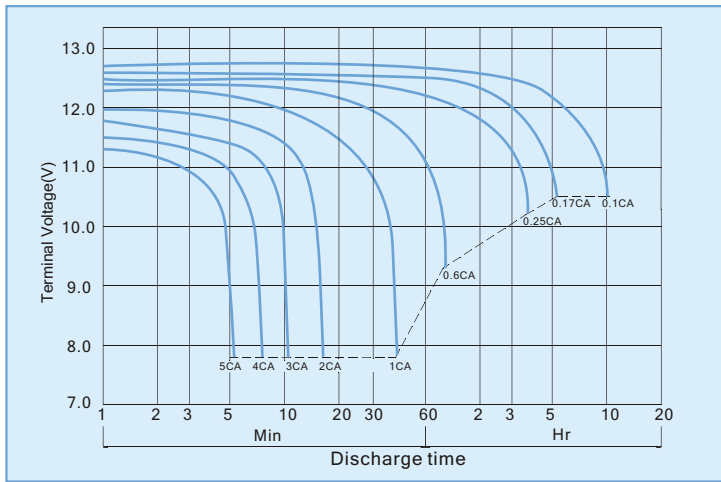

**Battery Charging Characteristics**

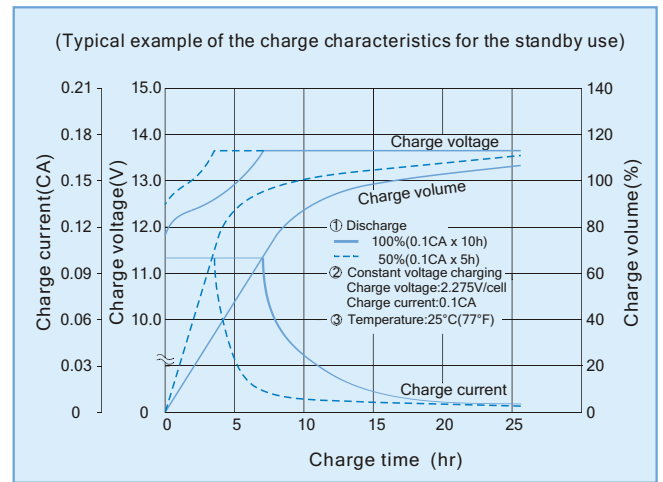

**Charging Procedure**

Application	Charging method	Charging Voltage at 25°C (V/cell)	Temperature compensation coefficient of charging voltage (mV/°C /cell)	Max. charging current (CA)	Charging time 0.1CA, 25°C (h)		Temp (°C)
					100% discharge	50% discharge	
For standby power Source	Constant voltage & Constant current charging (with current restriction)	2.25~2.30	-3	0.3	24	20	0~40 (32~104°F)
For cycle service		2.40~2.50	-4	0.3	16	10	

**Effect Of Temperature On Long Term Float Life**

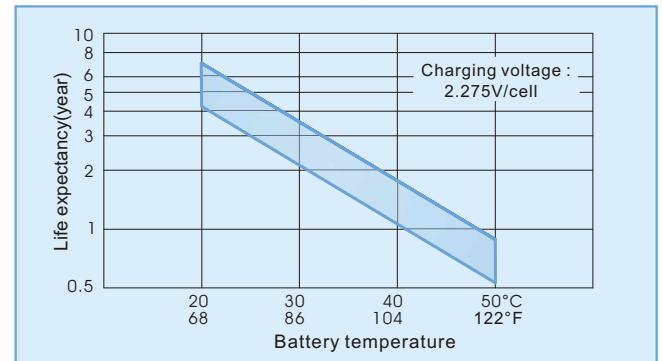

**Constant power discharge characteristics at 25 °C/77 °F Unit: W**

F.V. (V/cell) \ Discharge Time	5 Min	10 Min	15 Min	20 Min	30 Min	40 Min	50 Min	60 Min	120 Min
1.80V	328.0	224.0	172.3	138.4	105.2	80.0	66.8	58.8	32.4
1.70V	392.0	250.0	187.4	146.6	109.6	83.0	69.0	60.2	33.1
1.60V	420.0	263.0	195.9	152.0	112.0	85.0	70.4	61.2	33.6
1.50V	432.0	268.0	200.2	154.4	113.4	86.0	71.2	61.8	33.8
1.40V	440.0	271.6	202.5	155.8	114.2	86.6	71.8	62.2	33.9
1.30V	444.0	274.0	204.0	156.8	114.8	87.0	72.2	62.4	34.0

**Constant current discharge characteristics at 25 °C/77 °F Unit: A**

F.V. (V/cell) \ Discharge Time	5 Min	10 Min	15 Min	20 Min	30 Min	40 Min	50 Min	60 Min	120 Min
1.80V	29.29	19.65	14.92	11.87	8.92	6.73	5.59	4.90	2.70
1.70V	35.64	21.93	16.22	12.57	9.29	6.98	5.77	5.02	2.76
1.60V	38.18	23.07	16.96	13.04	9.49	7.15	5.89	5.10	2.80
1.50V	39.27	23.51	17.33	13.24	9.61	7.23	5.96	5.15	2.82
1.40V	40.00	23.82	17.53	13.36	9.68	7.28	6.01	5.18	2.83
1.30V	40.36	24.04	17.66	13.45	9.73	7.32	6.04	5.20	2.83

All data shall be changed without prior notice, BB reserves the right to explain and update the information contained hereinto.

A/0 REV. Jul. 2009

